

## ZW32 户外高压真空断路器 ZW32 Vacuum breaker

### 产品描述 Description

户外高压真空断路器是三相交流50Hz、额定电压12kV的户外高压开关设备。适用于开断、关合城市或农村配电系统的负荷电流、过载电流和短路电流。

Pillar type outdoor vacuum breaker is a kind of outdoor high voltage switch equipment with 50Hz three-phase alternating current and 12kV rated voltage. It applies to breaking and closing the load current, overload current and short-circuit current in cities or country power distribution system.

### 符合标准 Standard

IEC60947-1, IEC60947-2, IEC60947-4

ZW32-12系列柱式户外高压真空断路器是三相交流50Hz、额定电压12kV的户外高压开关设备。适用于开断、关合城市或农村配电系统的负荷电流、过载电流和短路电流。

ZW32-12 series pillar type outdoor vacuum breaker is a kind of outdoor high voltage switch equipment with 50Hz three-phase alternating current and 12kV rated voltage. It applies to breaking and closing the load current, overload current and short-circuit current in cities or country power distribution system.

### 参数Specification

项目 Item	单位 Unit	ZW32-12G/ T400-12.5	ZW32-12G/ T630-16	ZW32-12G/ T630-20
额定电压 Rated voltage	kV	12		
额定电流 Rated current	A	400	630	630
额定短路开断电流 Rated short-circuit breaking current		12.5	16	20
额定短路关合电流(峰值) Rated short-circuit closing current (Peak Value)	kA	31.5	40	50
额定峰值耐受电流 Rated peak value withstand current		31.5	40	50
额定短时耐受电流 Rated short-circuit withstand current		12.5	16	20
额定短路持续时间 Rated short-circuit duration	S	4		
额定绝缘水平 Rated insulation level	kV	相间、对地75、断口85 Interphase, grounding insulation 75, fracture 85		
雷电冲击耐受电压(峰值) Thunder impulse withstand voltage (Peak value)		相间、对地42、断口48 Interphase, grounding insulation 42, fracture 48		
Lmin 工频耐受电压 Lmin power frequency withstand voltage				
额定操作顺序 Rated operation order		分-0.3s-合 分-180s-合分(电动机构) Off-0.3s-on-off-180s-on-off (electromotion framework)		
额定短路电流开断次数 Breaking times of rated short-circuit current	次 (times)	30		
机构寿命 Mechanical life-span		10000		
额定操作电压(分合线圈) Rated operation voltage (on-off coil)	v	DC220,110,AC220		
动静触头允许磨损累计厚度 Automatic striling and grinding cumulative thickness	mm	3		
过电流脱扣器额定电流 Rated current of overcurrent trip	A	5		
电流互感器电流比 Current rate of current inductor		200/5 400/5 600/5		
触头开距 Contact distance	mm	9±1		
触头超程 Contact travel		20±0.5		
平均分闸速度 Average breaking speed	m/s	1.2±0.3		
平均合闸速度 Average closing speed		0.6±0.2		
分闸时间 Breaking time		30~60		
合闸时间 Closing time		20~40		
合闸弹跳时间 Bounce time of closing	ms	≤2		
三相分闸同期性 Corresponding performance of three-phase breaking & closing		≤2		
每回路直流电阻 Loop D.C. resistance of each phase	μΩ	≤80		
储能电机 额定电压 Rated voltage	V	220		
Power storage electro-moto 额定功率 Rated power	W	200		
储能时间 Energy-storing time	S	≤8		
重量 Weight	kg	125		

### 尺寸Overall and mounting dimensions(mm)

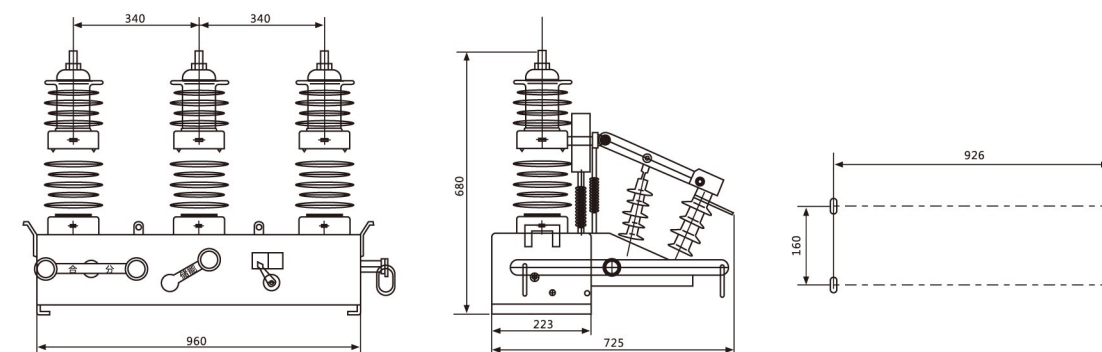

组合断路器外形尺寸 Breaker with disconnecting switch dimension